



FAST • FLEXIBLE • FOCUSED

Allied Mineral Technical Service, Inc. (AMTS) offers value added technical assistance in the critical areas of the blast furnace, hot blast stove and cupola. The AMTS team has decades of experience in the industry and is backed by Allied Mineral Products, a global leader in refractory technology and production.

AMTS Supports:

- Blast Furnaces
- Hot Blast Stoves
- Hot Blast Systems
- Casthouse Design
- Cupolas

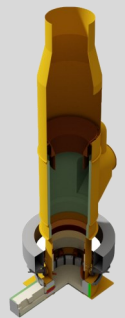
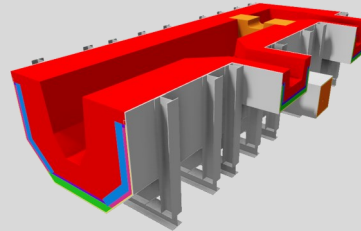

Engineering and Design Services

Our value added technical assistance includes a range of data collection and analysis and engineering design capabilities to help optimize furnace operation.

- Hearth monitoring and modeling
- Failure diagnostics of hearth and taphole
- Campaign extension
- New and spent refractory testing
- Advanced cooling systems
- STACKCRETE® high conductivity shotcrete

Field Services

Our team is on site providing supervision and assistance to ensure your operations run safely and efficiently. Our support includes:

- Assistance for:
 - Core drilling
 - Grouting
 - Installation
 - Maintenance
- Emergency responsiveness
- Data collection equipment placement
- Refractory properties and behavior monitoring
- Analysis of melt practices
- Training on refractory best practices

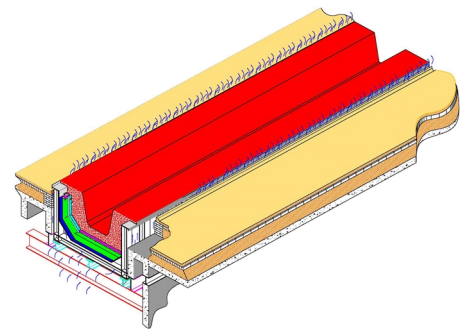
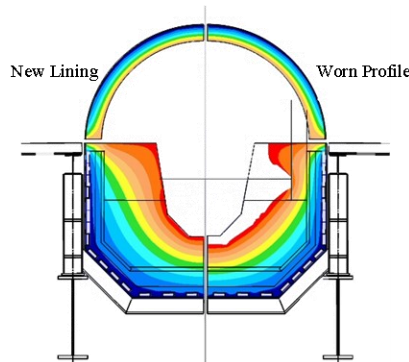
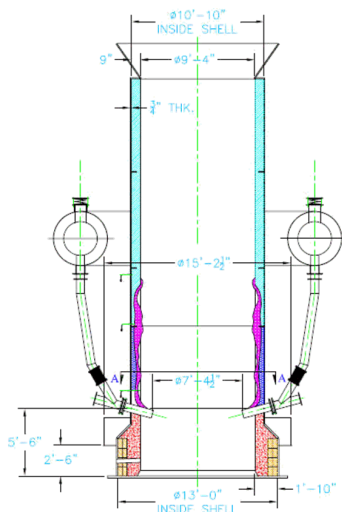

Allied Mineral Technical Services

AMTS@alliedmin.com | alliedmineraltechnicalservices.com





HOT BLAST STOVES

Allied Mineral Technical Service, Inc. (AMTS) works closely with Allied Mineral Products to provide value added assistance to critical areas of the Blast Furnace, Hot Blast Stove and Cupola.

AMTS Benefits:

- Value added technical services
- Provide a complete or partial package
- Design and engineering systems
- Direct refractory manufacturing and supply support through its partnership with Allied Mineral Products
- Full stove inspection

AMTS Capabilities:

- Precast refractory shape design and manufacturing
- Global sales and service network
- Field services
- System monitoring

AMTS Product Applications:

- Combustion chamber
- Hot blast main
- Dome
- Tuyere stocks
- Checker chamber

Research & Technology:

In addition to decades of experience in the industry, AMTS is supported by Allied Mineral Products' research and technology department to provide customized solutions for system designs and refractory issues.

Services include:

- Application specific product development and improvement
- Extensive testing capabilities
- Post mortem analysis
- Experience with the repair and design of traditional brick layouts—bricks, monolithics or a combination



Cast hot blast outlet



Pouring of combustion chamber wall

Allied Mineral Technical Services

AMTS@alliedmin.com | alliedmineraltechnicalservices.com





HOT BLAST STOVES PRODUCTS

Combustion Chamber and Dome

Product	Vibration Cast	Shotcrete	Ram / Plaster	Information
LCF 798A Pump	X	X		Extreme thermal shock resistance; suitable for lower combustion chamber
MATRIPUMP 60	X	X		Hot face and cold face wall suitable for the upper part the of the lower combustion chamber
LCF 61A	X			Suitable for the hot face dome and middle combustion chamber
MINRO-AL® PLASTIC A76			X	For patching and filling surface damage
BRICKMIX 61			X	Can be rammed or will air set
CW 366 PLASTIC FINE			X	For patching and filling surface damage
KASTITE 2800	X			Back-up insulation

Combustion Chamber and Checker Chamber

Product	Vibration Cast	Shotcrete	Mortars	Ram / Plaster	Information
BRICKSET			X		For use as insulation & hard brick mortar
Dural 65			X		Hard brick mortar
CW 108 PUMP	X	X			Suitable for back-up insulation
INSULMIX® 23	X			X	Suitable for back-up insulation
DURAGUN® 56				X	A hot gunnite repair material

Tuyere Stocks

Product	Vibration Cast	Shotcrete	Ram / Plaster	Information
LCF 798A Pump	X	X		Withstands extreme thermal shock and high hot blast temperatures
MATRIPUMP 60	X	X		Suitable for traditional design hot and cold face walls; Creates extra smooth surface finish
LCF 61A	X			Good resistance to both thermal shock and high temperatures
ULTRA FLO 70M	X			For high temperature applications

Allied Mineral Technical Services

AMTS@alliedmin.com | alliedmineraltechnicalservices.com

